

Precision coating systems for applying uniform thin film coatings

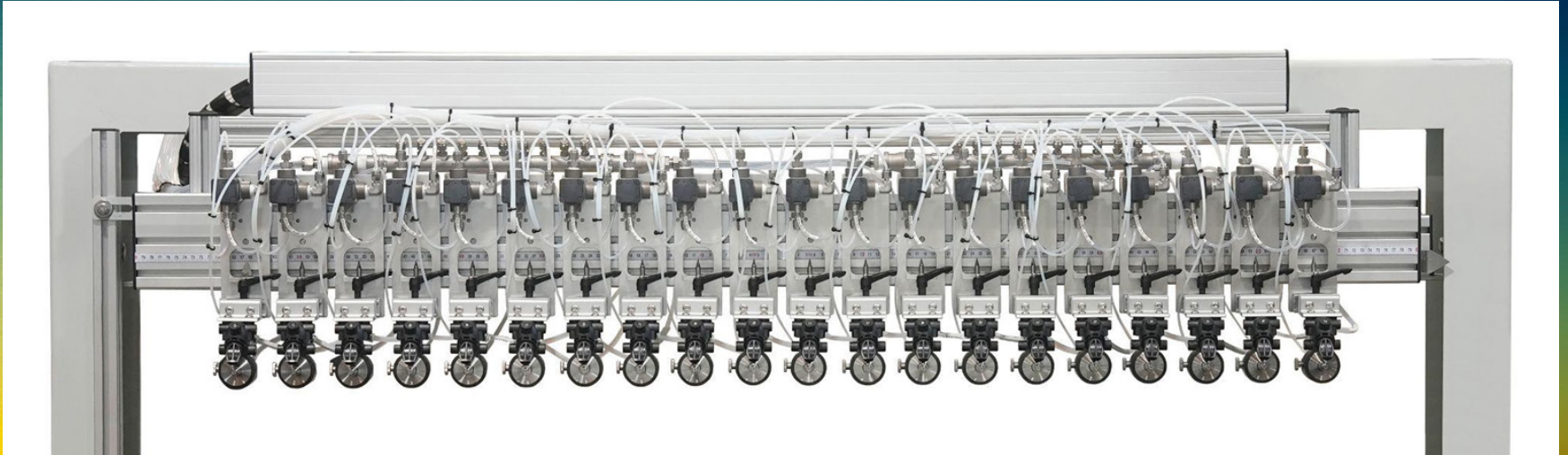

WideTrack Large Area High Volume Solar Manufacturing Coating System

SAFE HARBOR STATEMENT

This presentation contains forward-looking statements within the meaning of safe-harbor provisions of the Private Securities Litigation Reform Act of 1995. Such statements involve known and unknown risks, uncertainties, and other factors that could cause the actual results of the Company to differ materially from the results expressed or implied by such statements, including delivery of profitable, dynamic growth, growth opportunities for ultrasonic spray technology, retaining and expanding industry leadership and customer base, continuing product diversity, maintaining technological advantage of the Company's nozzles over those of competitors, including faster return on investment compared to conventional spray systems, enhancing global distribution network, establishing market niches for recently developed products and services, including fuel cell roll-to-roll development and controlled coating, market reception of new spray innovations, ability to increase sales of larger machines with longer delivery times, maintaining strong net cash position, achieving revenue projections, and other factors. Accordingly, although the Company believes that the expectations reflected in such forward-looking statements are reasonable, there can be no assurance that such expectations will prove to be correct. The Company has no obligation to update the forward-looking information contained in this presentation.

OVERVIEW

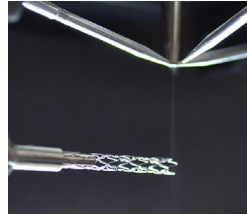

Cardiac Stent Coating

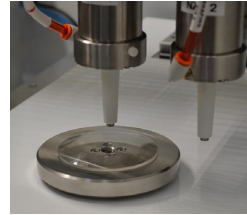

Glass Lens Coating

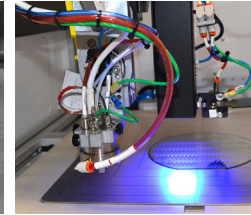

**Semiconductor
Photoresist Coating**

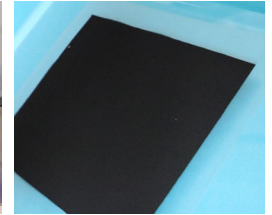

**Fuel Cell Catalyst
Coated PEM**

Sono-Tek Corporation is a global leader in the design and manufacture of ultrasonic coating systems that are shaping industries and driving innovation worldwide. Our ultrasonic coating systems are used to apply thin films onto parts used in diverse industries including microelectronics, alternative energy, medical devices, advanced industrial manufacturing, and research and development sectors worldwide. Sono-Tek's bold venture into the clean energy sector is showing transformative results in next-gen solar cells, fuel cells, green hydrogen generation, and carbon capture applications as we shape a sustainable future.

Our product line is rapidly evolving, transitioning from R&D to high-volume production machines with significantly higher average selling prices, showcasing our market leadership and adaptability. Our comprehensive suite of thin film coating solutions and application consulting services ensures unparalleled results for our clients and helps some of the world's most promising companies achieve technological breakthroughs and bring them to the market.

Sono-Tek's ~15,000 square foot manufacturing campus is located on Route 9 in Milton, NY, and houses our production factory as well as: engineering, sales and administrative offices, onsite testing laboratory and contract coating services, and shipping and warehousing areas.

INVENTORS OF ENVIRONMENTALLY FRIENDLY ULTRASONIC SPRAY NOZZLE TECHNOLOGY



An extensive portfolio of R&D through high volume coating systems

Sono-Tek Corporation (Nasdaq: SOTK) is the leading worldwide developer and manufacturer of ultrasonic spray coating systems for applying functional thin film coatings in 5 key market sectors:

- **MICROELECTRONICS/ELECTRONICS**
- **ALTERNATIVE ENERGY**
- **MEDICAL**
- **INDUSTRIAL**
- **EMERGING R&D MARKETS**



Ultrasonic atomizing nozzle, the "heart" of all Sono-Tek ultrasonic coating systems

ADDRESSABLE MARKETS



Market Strategy: Sono-Tek grows our business by targeting key disruptive coating applications in growth oriented sectors. The Company's sales are categorized into 5 main manufacturing sectors.

SUB-CATEGORIES OF MAJOR MARKETS:

- FUEL CELLS
- SOLAR CELLS
- HYDROGEN ELECTROLYZERS
- SEMICONDUCTORS
- NANOMATERIALS
- PRINTED CIRCUIT BOARDS
- ADVANCED TEXTILES
- FOOD & PACKAGING
- AUTOMOTIVE
- AEROSPACE
- FLOAT GLASS
- DISPLAYS & TOUCH SCREENS
- DIAGNOSTIC & IMPLANTABLE MEDICAL DEVICES
- BLOOD COLLECTION TUBES
- SENSORS

FY2024 SALES BY MARKET

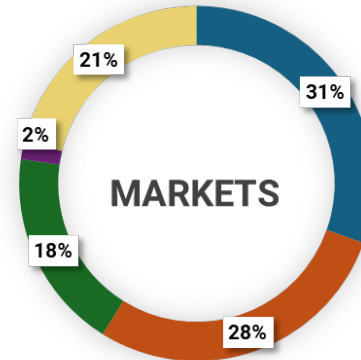

- ALTERNATIVE ENERGY
- ELECTRONICS
- INDUSTRIAL
- EMERGING R&D
- MEDICAL

A BROAD RANGE OF APPLICATIONS

Sono-Tek's coating technology excels in spray applications that require very thin (nano to micron thickness), repeatable, uniform liquid film coatings, from very small areas to continuous wide widths. Coatings applied may be protective or functional.

A handful of liquid suspensions and solutions that are commonly sprayed include:

- Various nanomaterials
- Antimicrobials and drugs
- Protective polymers
- Precious metal catalysts
- Semiconductor photoresist
- Electronics soldering flux

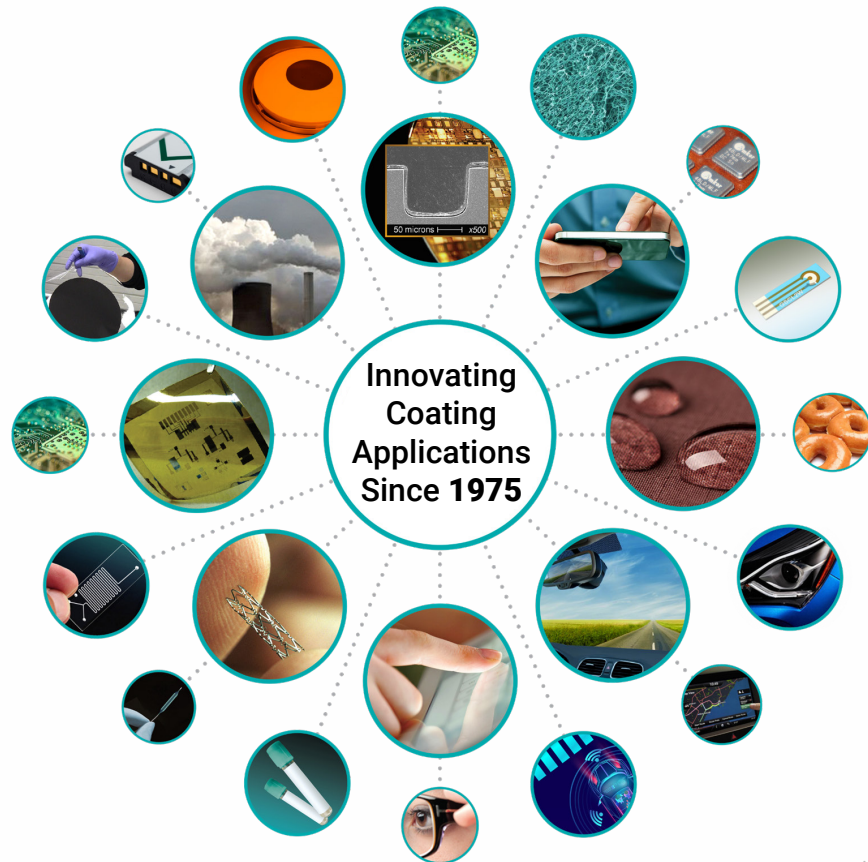

TARGETING KEY DISRUPTIVE MARKETS

Global Trends Driving Demand for Thin Film Coating Solutions

By entering disruptive markets in their infancy Sono-Tek gains a foothold in establishing ultrasonic coating as an industry standard. These emerging technologies are an important part of our growth strategy, with large upside potential.

Microelectronics/Electronics

- Demand for increasingly smaller footprint handhelds



Medical Devices

- Implantables, microfluidics, diagnostic testing applications

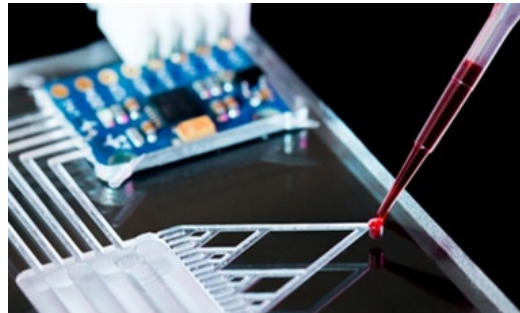

Alternative Energy

- Climate change and energy security are key drivers



TARGET MARKET: ALTERNATIVE/ CLEAN ENERGY

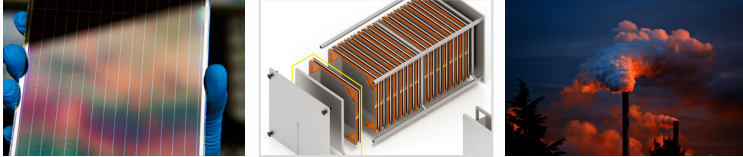

All of these applications use functional surface coatings that Sono-Tek applies exceptionally well, with greater efficiency, uniformity, scalability, and cost effectiveness than other deposition methods:

- **Green Hydrogen**
- **Electrolyzers**
- **Thin Film Solar Cells**
- **Fuel Cells**
- **Carbon Capture & Reuse**



Abundant research papers detail process advancements using ultrasonic spray.

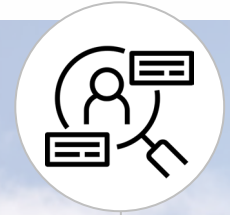

Sono-Tek equipment is entrenched in academia and R&D institutions.

Fossil fuel and CO2 reduction technologies are accelerating ultrasonic spray acceptance as an industry standard manufacturing process for leading global corporations. Sono-Tek is transitioning customers to high-volume manufacturing equipment solutions.

ADDRESSABLE MARKETS DEFINED BY APPLICATION

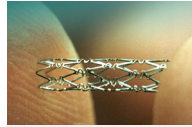

ESTABLISHED MARKETS (10+ YEARS)

- **Medical Devices**
Implantable stents, blood collection tubes
- **Printed Circuit Boards (PCBs)**
Wave solder fluxing processes
- **Industrial Float Glass**
Continuous glass production

Continuous improvement and service keep Sono-Tek at the forefront of these markets.



EMERGING MARKETS

- **Microelectronics**
Small footprint devices (EMI shielding, photoresist, nanomaterials)
- **Medical Devices**
Diagnostic devices, balloons, implantables, microfluidics
- **Protective & Functional Coatings**
Automotive plastics, glass, sensors

Unique capabilities make Sono-Tek a good fit for new high growth applications.

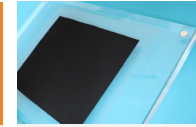

TRANSITIONING MARKETS

- **Fuel Cells/Electrolyzers**
Catalyst coatings for Proton Exchange Membranes (PEMs), carbon capture, green hydrogen generation
- **Medical Devices**
High volume coatings for implantable devices

Large customer base using our systems for R&D, transitioning to production volumes.

GROWTH STRATEGY

There are 4 main aspects to Sono-Tek's business strategy for growth. By leveraging these strengths and unique capabilities, Sono-Tek is positioned to continue gaining significant market share in the ultrasonic coating segment as well as the overall global coating equipment market.



Semiconductor Photoresist Coating Machine

FULL SYSTEM
SOLUTIONS

SCALABLE
MANUFACTURING
EQUIPMENT

APPLICATION
ENGINEERING
EXPERTISE

INTERNATIONAL
LEGISLATIVE ACTION &
CORPORATE SPENDING

FULL SYSTEM SOLUTIONS

Increased Customer Value with Rapidly Expanding Average Selling Prices (ASPs)

Custom engineered solutions with pre-and-post processing stations, auto load function and custom part handling are possible with extensive experience and strong customer relationships with industry leading companies.

- State-of-the-art custom engineered solutions.
- Advanced technical capabilities to solve customer coating challenges.
- Established network of industry equipment partners for large system integration projects.
- Expansion of product portfolio with application specific machinery.
- New applications in high tech markets for large platform systems.

OUR STRATEGY IS WORKING TO ACHIEVE:

- *Recognition as an **innovative technology company** with **powerful proprietary knowledge***

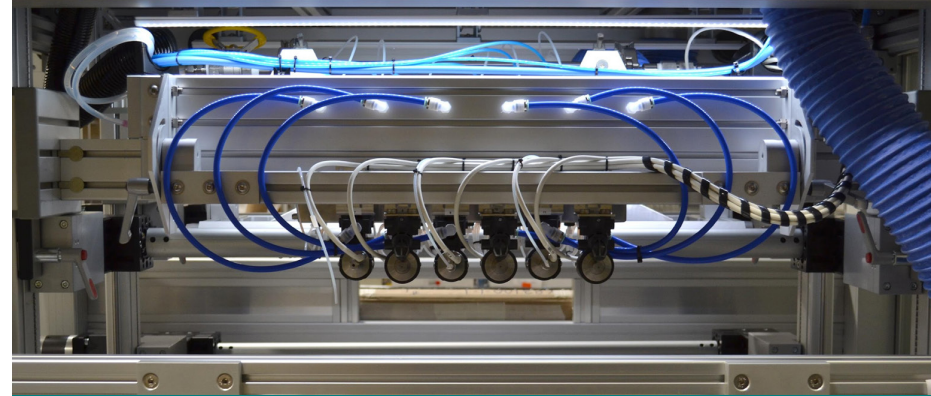

Advanced textile wide area coating system

SCALABLE MANUFACTURING EQUIPMENT

Proven Scaling from R&D to Production Volume

Sono-Tek coating equipment is easily scaled to higher volume processes once R&D process development is fine tuned. Following their R&D phase, customers can transition to a pilot scale system, followed by a high volume production line. The same core nozzle technology drives small scale R&D through continuous high volume production coating machines.

- Customers are often using R&D machines and looking to increase production after process development.
- Dramatically higher ASPs are achieved on full system solutions with complex product handling and pre/post coating stations.
- Latest high volume production systems can exceed \$1M+.

R&D



PILOT SCALE



HIGH VOLUME PRODUCTION



APPLICATION ENGINEERING EXPERTISE

Focusing on Customers' Unique Needs Ensures Success

Enhanced customer support with process development ensures that our equipment performs exceedingly well, and nurtures strong customer relationships. Our team of applications engineers provides a technical bridge between sales and customers, including testing, process development, contract coating, and machine specification.

- Complex, customized machine solutions give us a distinct competitive edge.
- On-site laboratory testing, customer visits and support ensure customer success, accelerate and expand orders.
- Strategic partnerships with chemical companies.
- 6 worldwide labs support customer process development.

MILTON, NY US DEVELOPMENT LAB



INTERNATIONAL LEGISLATIVE ACTION & CORPORATE SPENDING

Sono-Tek is well positioned in markets that are being heavily funded through government and legislation initiatives that are expected to contribute to the Company's overall growth in 2024 and beyond.*



Chips Act

Over \$200B for high tech research and semiconductor manufacturing.

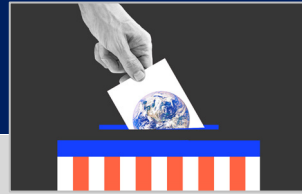

Climate Bill

\$369B focused on reducing 40% of greenhouse emissions by 2030.



South Korea Green New Deal

\$135B investment in both green energy and digital technologies.



REPowerEU

Over 210B Euros to reduce energy dependence, focused on transitioning to clean energy and a net-zero carbon goal by 2050.

** Hundreds of government initiatives in these areas are currently taking place worldwide.*

CORE ULTRASONIC NOZZLE TECHNOLOGY IS AT THE HEART OF EVERY MACHINE

Ultrasonic nozzle systems use high frequency ultrasonic vibrations to atomize liquids into uniform micron-sized drops for coating a wide variety of surfaces.

- + Firmware/software
- + Electronics
- + Precision hardware

UNIQUE PROPRIETARY TECHNOLOGY
A software driven, electro-mechanical droplet generator, perfect for high-tech precision coating applications.

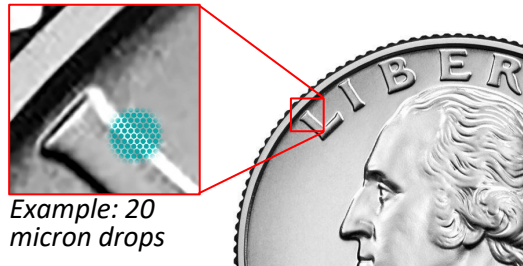
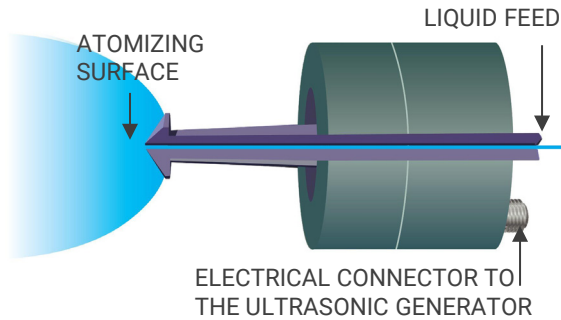

Example: 20 micron drops

Every Sono-Tek coating system uses our proprietary ultrasonic spray nozzle technology at its core. Liquid delivery, spray shaping and generator controls are fully integrated into automated full coating solutions with software control, product handling and customized options.



ULTRASONIC SPRAY ADVANTAGES

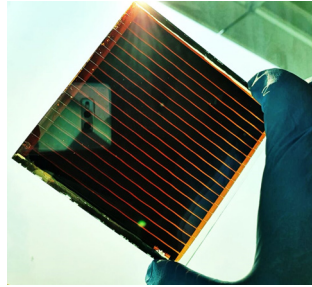

This example of a Perovskite solar cell coating application shows precise coating with controllable surface morphology characteristics achieved with Sono-Tek technology.

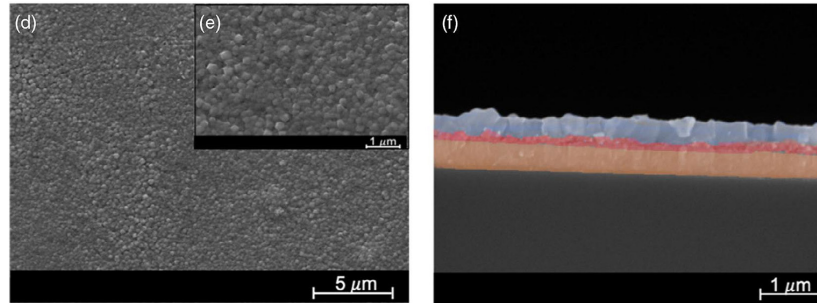

PEROVSKITE SOLAR COATING APPLICATION

Photo: www.solar-rrl.com, Spray-Coated Lead-Free Cs₂AgBiBr₆ Double Perovskite Solar Cells with High Open-Circuit Voltage

More cost-effective and simpler than alternative coating methods:

- Dramatic reductions in overspray with reduced emissions
- Large cost savings
- Improved process repeatability
- High precision thin films
- Increased uniformity of coatings

PRODUCT PLATFORMS

Our coating systems include 4 platform types, each with a line of unique machine offerings. Machines incorporate industry specific hardware options as well as unique product handling and customized options that are used in many diverse applications.

PRODUCT TYPES



One example of each product type shown

1. OEM SPRAY DRYING KIT
2. FLUXING SYSTEM
3. INTEGRATED NOZZLE ARRAY
4. MULTI AXIS SYSTEM

FY2024 SALES BY PRODUCT TYPE

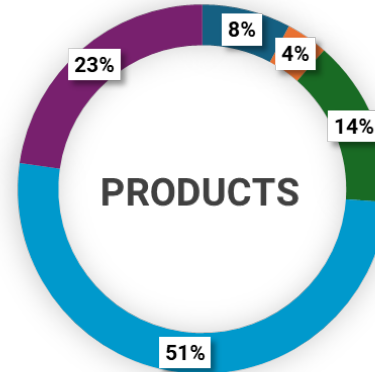

- OEM SYSTEM
- FLUXING SYSTEMS
- INTEGRATED COATING
- MULTI AXIS COATING
- OTHER

R&D THROUGH
HIGH VOLUME
PRODUCTION LINES

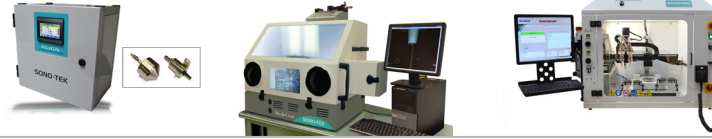

*A small sampling
of Sono-Tek's specialized
coating systems*



NEW PRODUCT DEVELOPMENT

We are continuously expanding our product lines to help us reach broader markets. Product development is led by:

- In-house engineering capabilities, including mechanical, electrical, control software and application engineering teams.
- Established equipment partners for large integration projects.
- Application engineering team works with customers to develop coating process and sales team to qualify success of applications that align with market demand.
- Customer demand, often for coating solutions that don't exist elsewhere and don't have an industry standard.
- Robust quality systems that drive advancements and updates to existing products and next generation models.

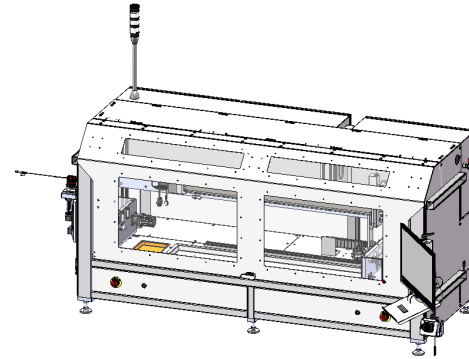

INITIAL PHASES OF NEW PRODUCT DEVELOPMENT



Sales team gauges customer needs and budget

Application engineering team determines application feasibility and guides customer through coating development process

Engineering team develops systems driven by order expectation



FINANCIAL HIGHLIGHTS FY2024

\$19.7M SALES
31% GROWTH IN FY2024

We reported record breaking revenue in FY2024 and record breaking backlog for the year ahead

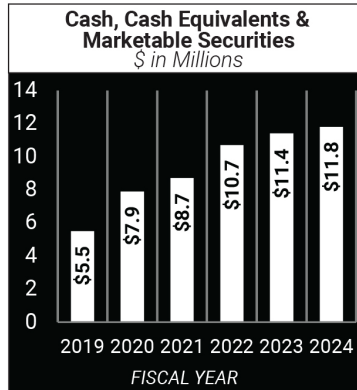
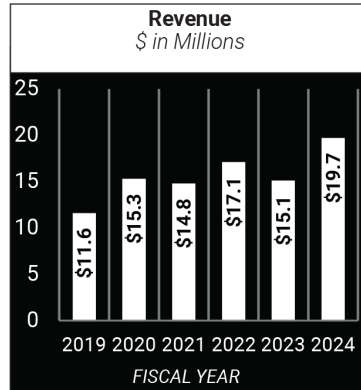

MARKET DATA 6.20.2024

Nasdaq	SOTK
Stock Price	\$4.11
52 Week Range	\$3.62-\$6.12
Market Cap	66.00M
Average Daily Trading (3 Months)	7.26K
Common Shares Outstanding	15.75M
Insider Ownership	7%
Cash, Cash Equivalents & Marketable Securities (FY2024)	\$11.84M

EARLY PHASE NEW REVENUE STREAMS GAINING MOMENTUM

Services Revenue Increasing

- Service-related contracts that support our large platform and highest ASP production lines are growing in importance.
- Our in-house development lab generates increasing revenue streams while accelerating orders.

SERVICE DEPARTMENT REVENUE

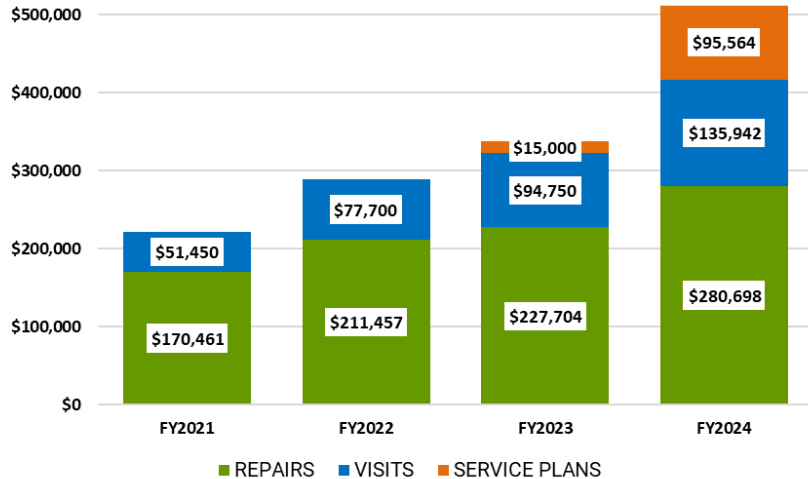

DEVELOPMENT LAB PAID SERVICES REVENUE

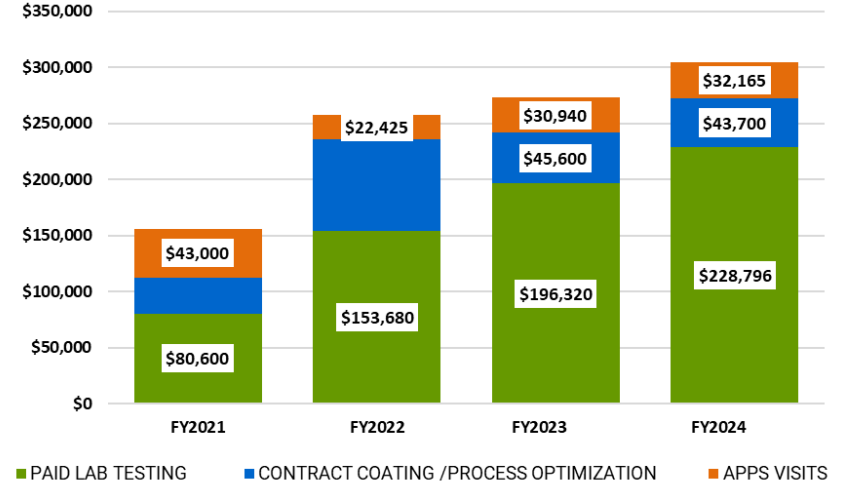

AVERAGE SELLING PRICE (ASP) PROGRESSION

Increasing % of Sales with High ASPs

From FY2017 to FY2024:

- \$5M increase in sales over \$150k value per machine.
- \$4.7M increase in sales \$75-150k value per machine.
- Trend toward higher ASP systems expected to continue in FY2025 and beyond.

Focused on Expanding high ASP Segment

STRATEGIC FOCUS TOWARD HIGHER ASPs IS SHOWING SUCCESS

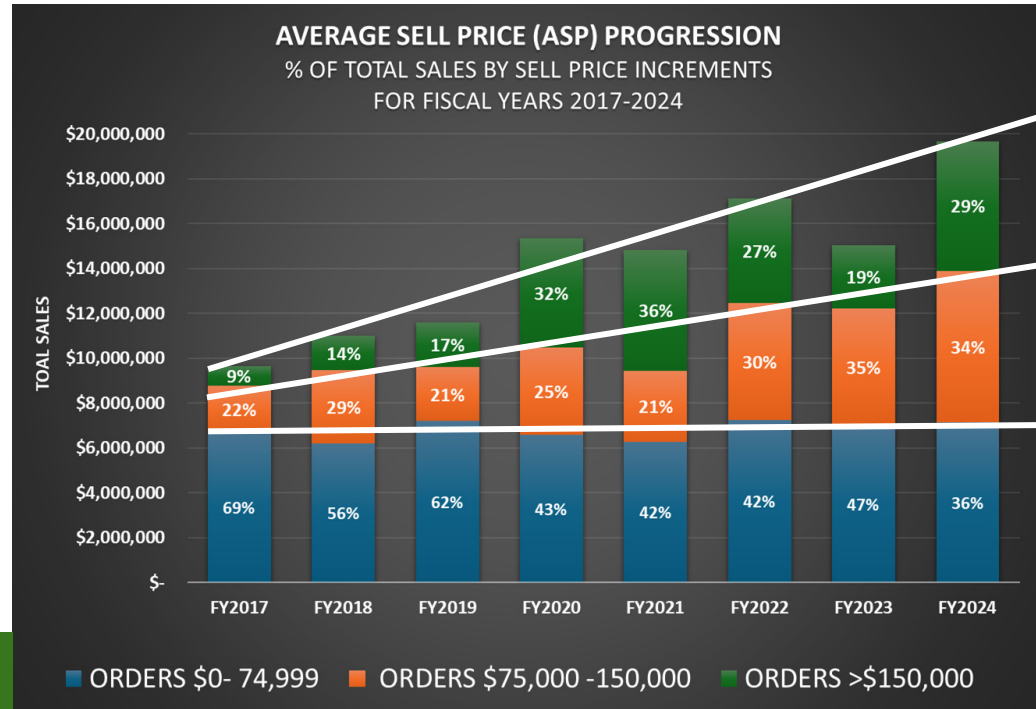

RECORD SALES IN FY2024

REVENUE (IN MILLIONS)

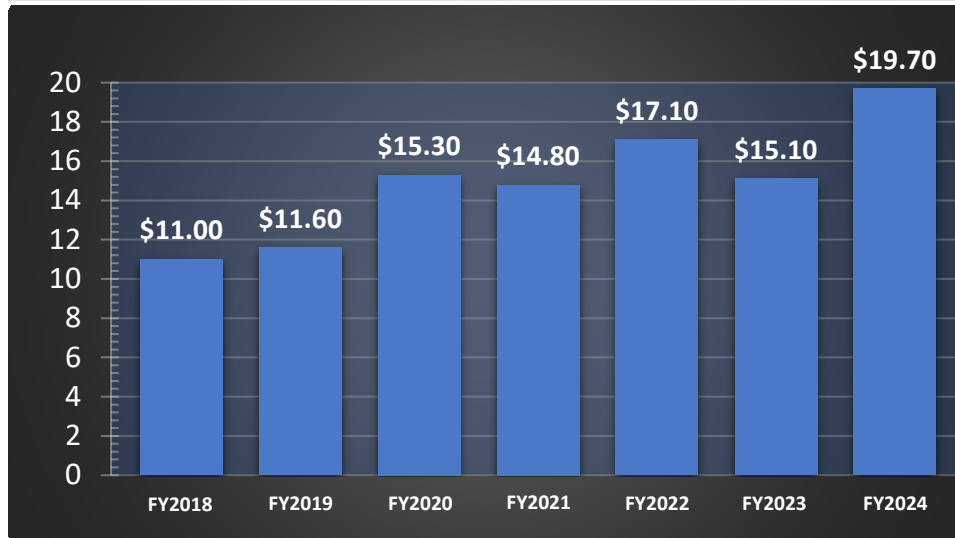
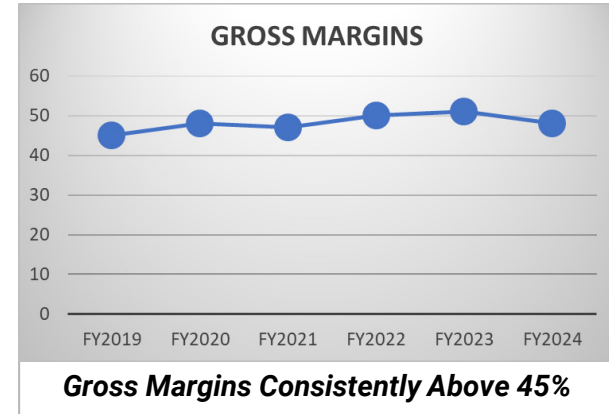
**Consistent Profitable Growth**

- \$11.84M Cash & Cash Equivalents
- Zero debt since FY2021
- Consistent positive cash flow

STRONG FY2025 OUTLOOK

- Project additional orders from key target markets.
- High activity levels in development labs.
- Backlog and revenue can be lumpy due to high ASP system shipments.
- Significant portion of customer base have long-term contracts with their customers, supporting Sono-Tek's future growth.
- Well positioned for continued growth in FY2025 and the years beyond.

BACKLOG (IN MILLIONS)



ULTRASONIC SPRAY MARKET SHARE

GENERAL COATING EQUIPMENT MARKET
~\$8B/yr Hundreds of Competitors

The general coating equipment market has enormous growth potential at \$8B per year. Sono-Tek continues to capture a growing segment of the coating equipment market with the accelerating recognition of ultrasonic coating technology as a reliable proven alternative to many conventional coating technologies and equipment providers. We intend to introduce ultrasonic spray coating as a viable disruptive technology in high growth potential markets globally.

■ = Ultrasonic Coating

Other Coating Technologies include:

- CVD
- Jetting
- Roller
- Slot Die
- Screen Print
- Dip Coating
- Sputtering
- Pressure Spray/
Air Atomizer

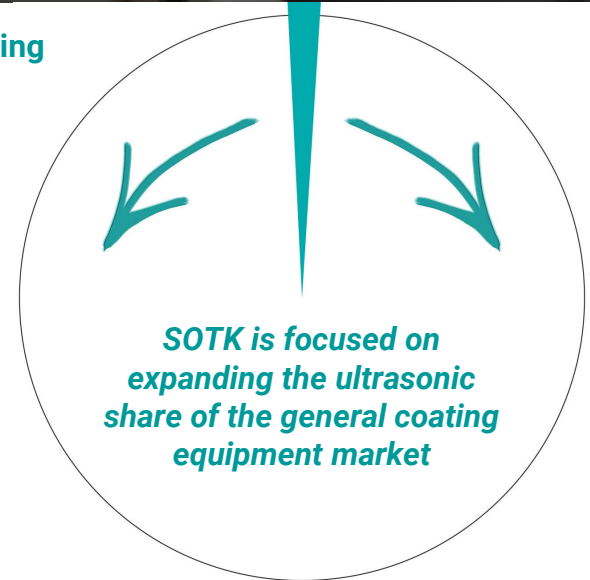

ULTRASONIC SPRAY GLOBAL COMPETITION

We have the leading market position in our industry

- Approximately 30 companies have attempted to copy Sono-Tek's technology, but none have gained significant market share, with many frequently opening and closing, leaving customers stranded.
- Smaller competitors can't provide complex solutions and application support, while Sono-Tek's substantial R&D investment ensures it remains the sole provider of comprehensive, high-volume manufacturing systems.
- Global manufacturers are risking exposure of proprietary intellectual property when choosing to do business with China-based competition versus Sono-Tek.
- Sono-Tek's growing customer base is fueled by fortune 500 size industry leading companies, uniquely differentiating us from the competition.



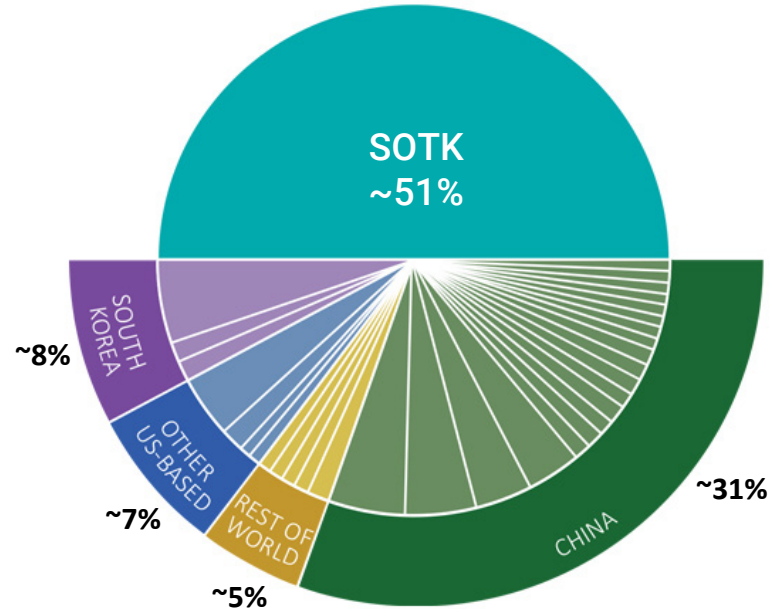

ULTRASONIC COATING EQUIPMENT

~\$41M/yr

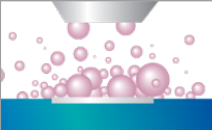

Note: Estimated data compiled from internal Sono-Tek sources

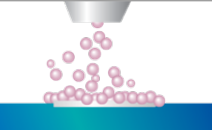
ULTRASONIC THIN FILM COATING VS OTHER COATING TECHNOLOGIES

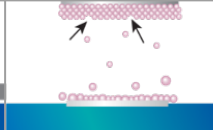
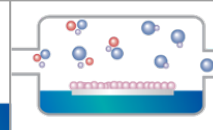
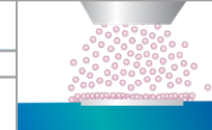
							
DEPOSITION METHOD	PRESSURE SPRAY/ AIR ATOMIZATION	DIP COATING	JETTING	SCREEN PRINTING/BLADE	SPUTTERING	CHEMICAL VAPOR DEPOSITION (CVD)	ULTRASONIC SPRAY
HOW IT WORKS	Liquid is forced through a very small orifice under high pressure	Substrate is dipped into material	Similar to a home office inkjet printer, ejecting tiny drops	Spreading a paste with a blade over a substrate	Ejecting particles from a target by bombardment with high energy particles	Creates a reaction between gases over a substrate, which condense on its surface	High frequency sound waves create mechanical vibrations, forming droplets with very little kinetic energy
DISADVANTAGES COMPARED TO ULTRASONIC SPRAY	<ul style="list-style-type: none"> • High velocity spray bounces off substrate, wasting material • Prone to clogging, high maintenance • Poor repeatability over time 	<ul style="list-style-type: none"> • Long drying times • Cannot create thin films • Requires large amount of material, large amount of waste 	<ul style="list-style-type: none"> • Uneven dispensing • Poor tolerance to abrasive chemicals • Prone to clogging, high maintenance 	<ul style="list-style-type: none"> • Requires minimum viscosity • Poor uniformity on very thin coatings • Requires large amount of material 	<ul style="list-style-type: none"> • Very expensive • Poor transfer efficiency • Slow batch process 	<ul style="list-style-type: none"> • Expensive to scale up • Very high operating expenses • Poor material usage 	ADVANTAGES <ul style="list-style-type: none"> • Uniform drop sizes • Operates with small amount of material • Does not clog • Easily scalable • Environmentally friendly
COST	\$	\$	\$\$\$	\$\$\$\$	\$\$\$\$\$	\$\$\$\$\$	\$\$

MANAGEMENT

EXECUTIVE & SENIOR MANAGEMENT

Experienced, dynamic committed leadership team



Dr. Chris Coccio
EXECUTIVE
CHAIRMAN

23 YEARS



Steve Harshbarger
CEO & PRESIDENT

31 YEARS



Stephen Bagley, CPA
CFO

19 YEARS



Maria Kuha
VP, MANUFACTURING
OPERATIONS

17 YEARS



Chris Cichetti
VP, SALES &
APPLICATION
ENGINEERING

16 YEARS

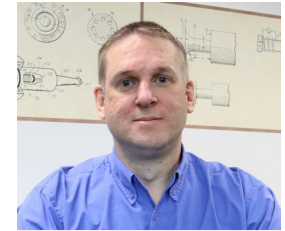

Randy Copeman
CHIEF
TECHNOLOGIST

27 YEARS

OVER 100 YEARS OF COMBINED EXPERTISE IN ULTRASONIC COATING TECHNOLOGY AT SOTK

COMPANY HISTORY

TIMELINE OF SIGNIFICANT MILESTONES

- 2024** FACTORY EXPANSION ON CAMPUS
- 2023** PLC PLATFORMS ADDED TO EXPAND ADDRESSABLE MARKET
- 2022** UPLISTED TO NASDAQ
- 2020** EXPANSION OF MANUFACTURING SPACE FOR LARGE PLATFORM SYSTEMS
- 2013** APPLICATION LABS OPEN IN GERMANY, JAPAN, CHINA, TAIWAN, KOREA, TURKEY
- 2010** MID-SIZE PLATFORMS FOR MICROELECTRONICS & MEDICAL SECTOR
- 2007** SONO-TEK PURCHASES MILTON INDUSTRIAL PARK
- 2005** SMALL MULTI AXIS COATING PLATFORMS INTRODUCED "EXACTACOAT" FOR R&D
- 2000** SMALL PLATFORM MEDICAL SYSTEMS INTRODUCED "MEDICOAT DES" STENT COATER
- 1997** ISO 9001:2000 CERTIFIED
- 1988** 1ST SMALL FULL SYSTEM INTRODUCED "SONOFLUX" SPRAY FLUXING PLATFORM
- 1987** SONO-TEK INITIAL PUBLIC OFFERING
- 1975** 1ST ULTRASONIC NOZZLE IS INVENTED & PATENTED BY SONO-TEK'S FOUNDER, DR. HARVEY BERGER



GEOGRAPHY

Extensive worldwide distribution network of factory-trained professionals and development laboratories for testing and process development leads to strong customer partnerships.



FY2024 SALES BY GEOGRAPHY

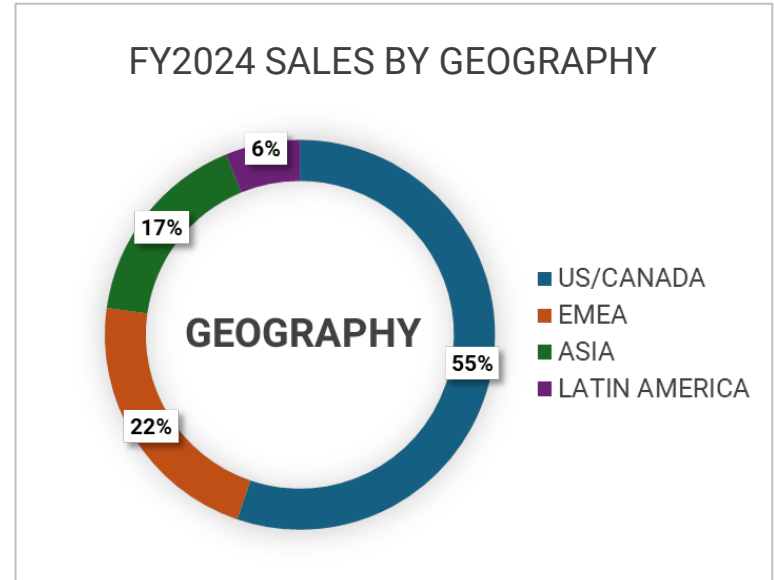

SUMMARY

***Advancing
Generational
Technology
Developments***

***Ramping Up
Clean Energy
Production***

***Consistently
Profitable with
Growing Revenue***

***Record Sales &
Backlog
in FY2024***

Poised for Success - Our business is taking off along with that of our customers

- *We are attached at the hip with our customers' success as they transition from R&D to production scales systems.*
- *We have the leading market position in our industry.*
- *Significant wins contribute to strong revenue tailwinds and drive growth.*
- *Our growth is accelerated by successfully shifting to larger production systems that drive the need for multiple machines.*
- *Our strategic growth initiatives should position us for higher revenue and increased profits in the coming years.*

SONO•TEK Corporation

Making an impact on our world

info@sono-tek.com

Dr. Christopher Coccio, Executive Chairman

CLCoccio@Sono-Tek.com

Steve Harshbarger, CEO & President

Harsh@Sono-Tek.com

Investor Relations:

PCG Advisory, Kirin Smith

ksmith@pcgadvisory.com

